

MARINE

NAVY SHIPS
RESEARCH SHIPS
CRUISE SHIPS
MERCHANT SHIPS
MEGA YACHTS
OFFSHORE-PLATFORMS
ALL SHIPS AT SEA

REVERSE OSMOSIS DESALINATORS
MEMBRANE BIO-REACTORS (MBR)

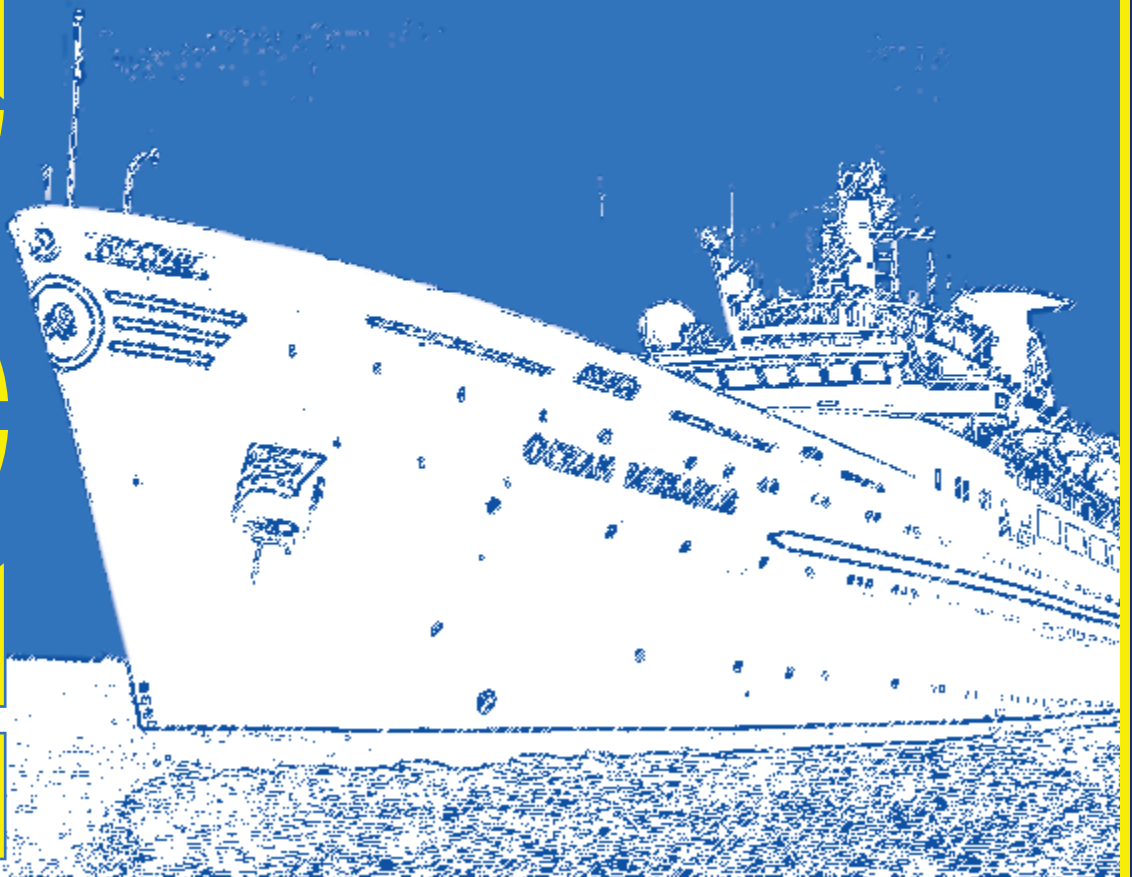

ROCHEM[®]

Technical Services

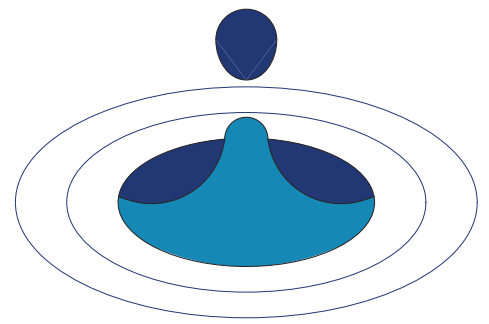

REVERSE OSMOSIS DESALINATION SINCE 1982

SINCE 33 YEARS ON MERCHANT SHIPS
CUSTOMER SATISFACTION
ON BOARD

1982

first RO unit

Dietrich Oldendorff

20.000 ltr. potable water



2015

Georg Oldendorff

35.000 ltr. potable water



ROCHEM®

Technical Services

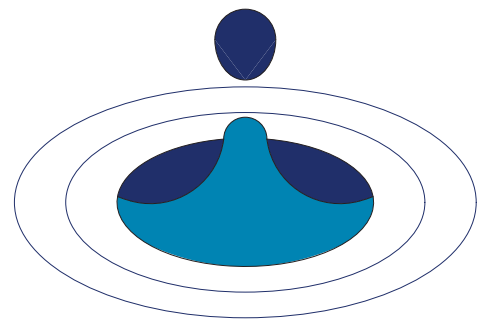

How does Reverse Osmosis work?

Pressure is applied to saline water to force the pure water molecules through a semi-permeable membrane. The majority of the dissolved salts, organic material, bacteria and suspended solids are unable to physically pass through the membrane and are discharged from the system in the rejected brine. The pure water is then ready for use without further treatment.

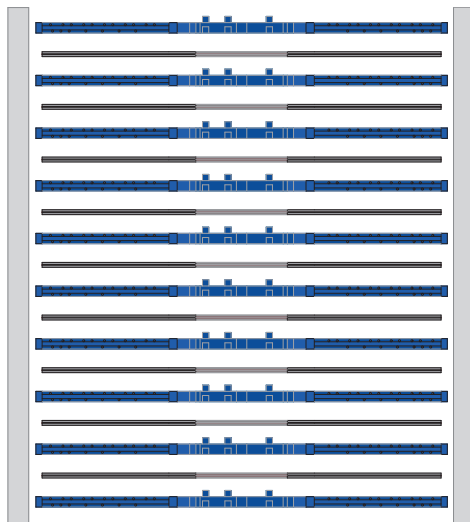
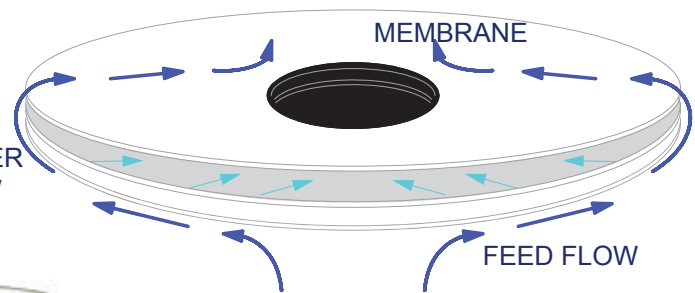
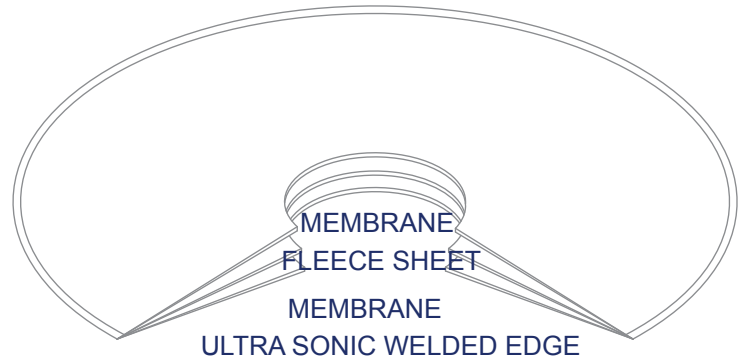
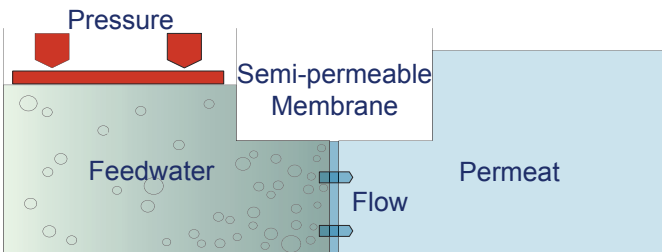

Depending on the type of membrane, the selective separation of certain individual substances or substance mixtures is possible. Important technical applications including the production of drinking water by reverse osmosis and in waste water treatment.

With the help of UF and MF (Ultra/Microfiltration) it is possible to remove particles, colloids and macromolecules, so that waste-water can be disinfected in this way. This is needed if waste-water is discharged into sensitive waters.

NEW
MODULE TYPE:
PF/ PLATE AND FRAME MODULE

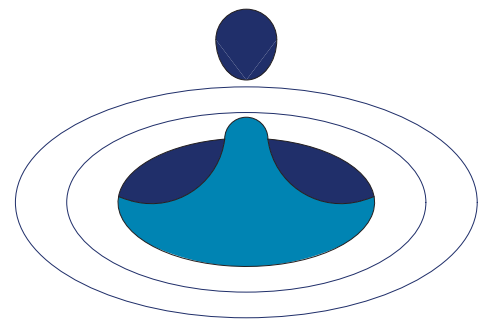

TRIPLE S/ TS MODULE

SELECTIVE SUBSTANCE SEPARATION

The significant difference to conventional spiral wound modules is that RocheM Technical Services combines different feed channels, permeate carriers and membranes in one module element.

THIS IS NEW, developed by RocheM Technical Services

Rochem Technical Services is able to create a module especially for your requirements.

The module element can be split into parts.
Each part includes different feed spacers and membranes;
also the membrane cushion carriers can be different.
R.T.S. RocheM Technical Services has a lot of possibilities to find
the ideal composition for your particular objectives.

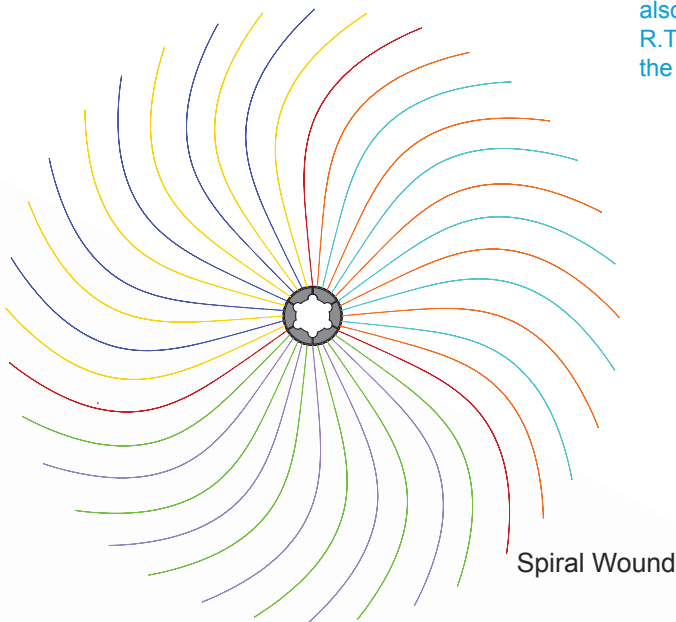

Spiral Wound

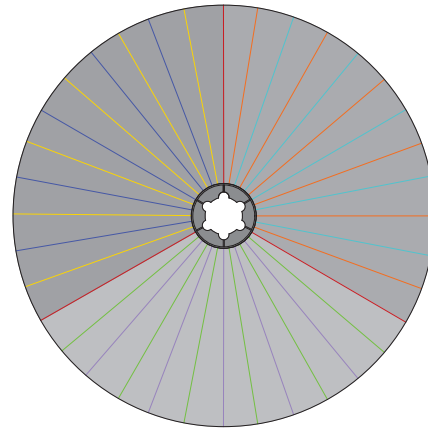

MEMBRANE- PERMEATE CARRIER- MEMBRANE / FEED SPACER

The heart of the TS module is the membrane element. This consists of membrane cushions and spacers wrapped in a tube element. The completed membrane element is then pushed on the rod-shaped permeate outlet and collecting device. The membrane element is provided with end flanges on both sides. The end flanges consist of at least one input for the feed medium to be separated and one output for the retentate. The border elements are kept sealed to the tube element. The TS element is covered in a pressure vessel.

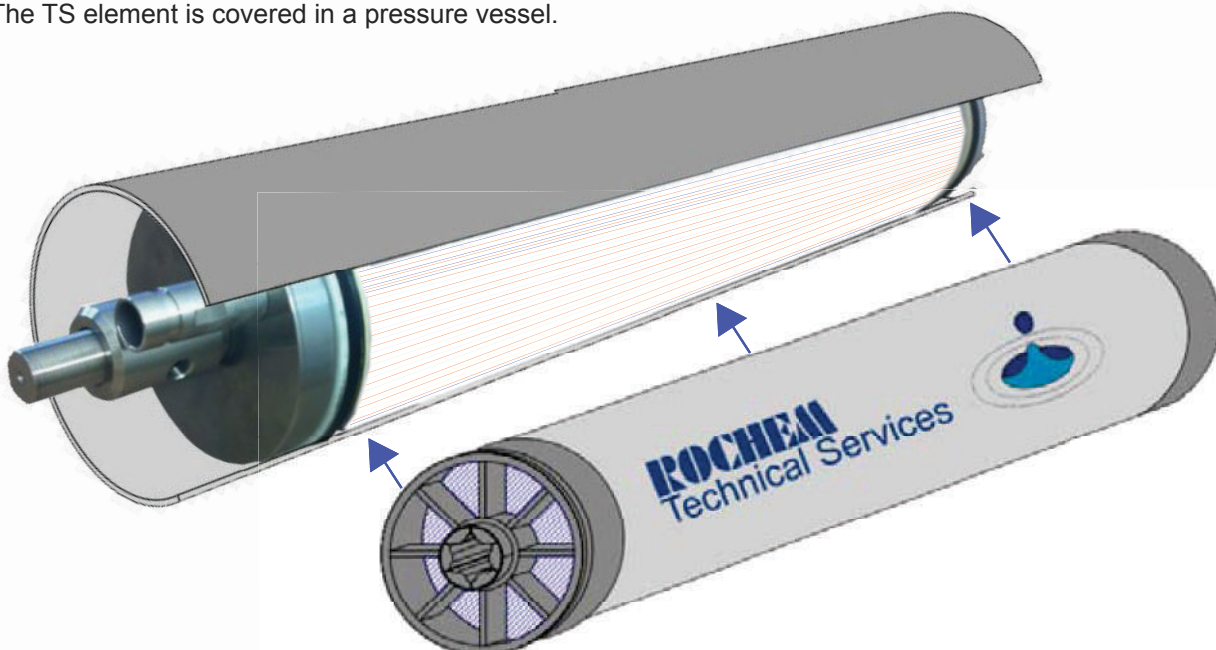

ROCHEM®

Technical Services

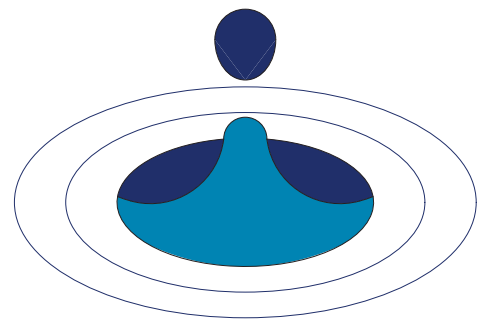

FOR OVER 20 YEARS ROCHEM REVERSE OSMOSIS PLANTS ARE PRODUCING FRESH WATER ON THE AMERIGO VESPUCCI, we are also on the:
Alexander v Humboldt, Frédéric Chopin, Gloria, Greif, Lilli Marleen, Mary Anne, Mephisto, Sagres, Staatsraad Lehmkuhl, Thor Heyerdahl, Zawisza Czarny

ROCHEM®

Technical Services

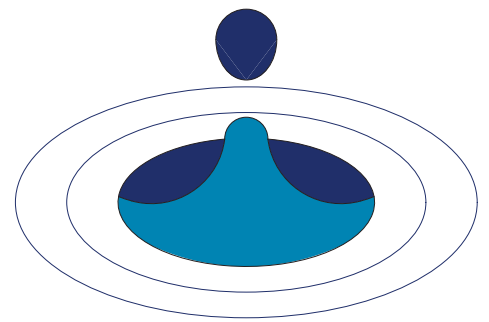

STANDARD ROCHEM
FRESHWATER GENERATORS FROM
2000 ltr/day up to 100.000 ltr/day
potable water



Type: RO 0510-PF2-10S



ROCHEM FRESHWATER GENERATORS
ON CUSTOMER'S REQUEST,
special design
FROM 250.000 ltr/day up to 500.000 ltr/day
potable water

FROM SEAWATER OF ALL OCEANS INTO FRESHWATER

ROCHEM®

Technical Services

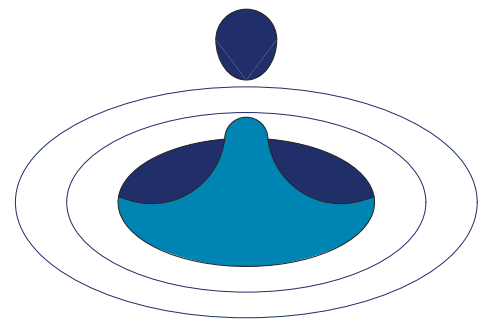

ROCHEM SEAWATER SYSTEM
300 m³ / day
automatic operation

WE PRODUCE THE POTABLE WATER FROM SEA, WITHOUT CHEMICALS DURING OPERATION

ROCHEM®

Technical Services

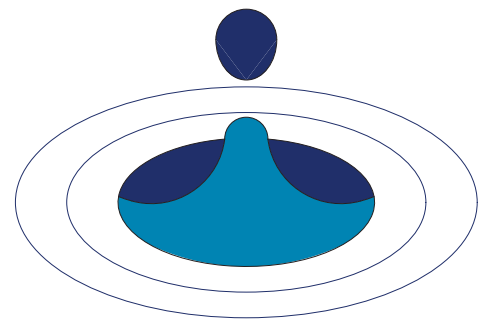

ROCHEM® REVERSE OSMOSIS FRESHWATER for naval surface ships and submarines:

Are designed to fulfill all Naval requirements, such as shock resistance, EMC low, airborne- and structure borne noise emission, a-magnetic design, etc. according to NATO STANAG regulations.

Are unique for the installation in submarines

SEAWATER DESALINATION

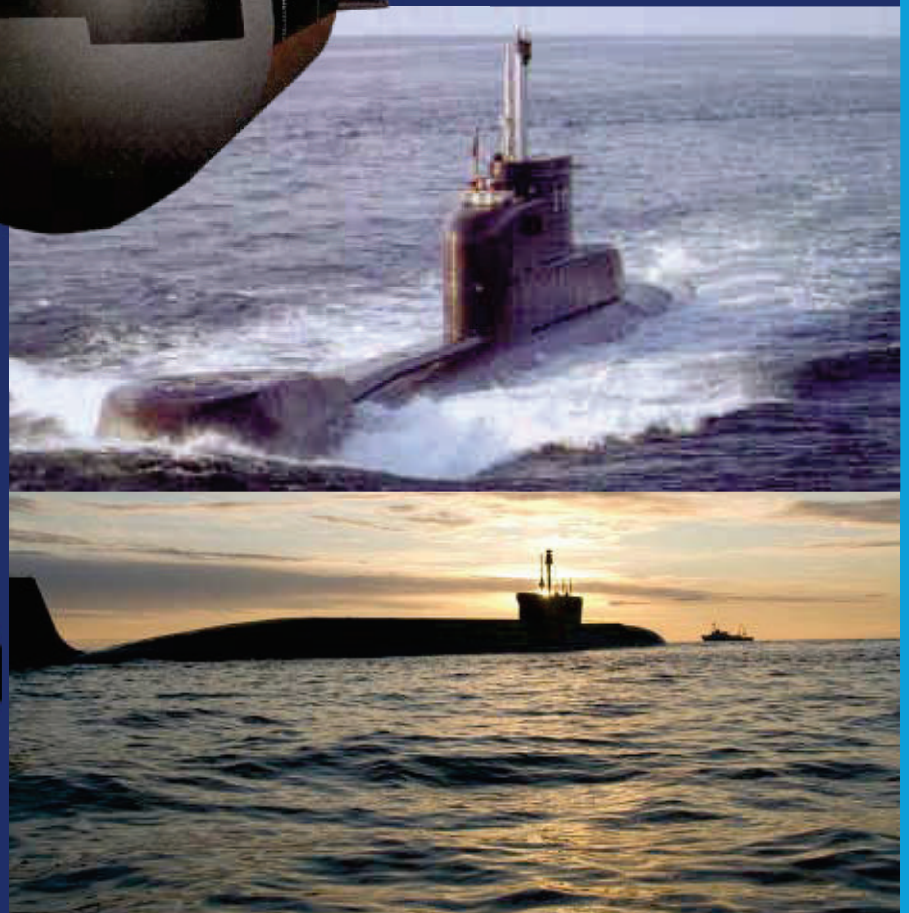
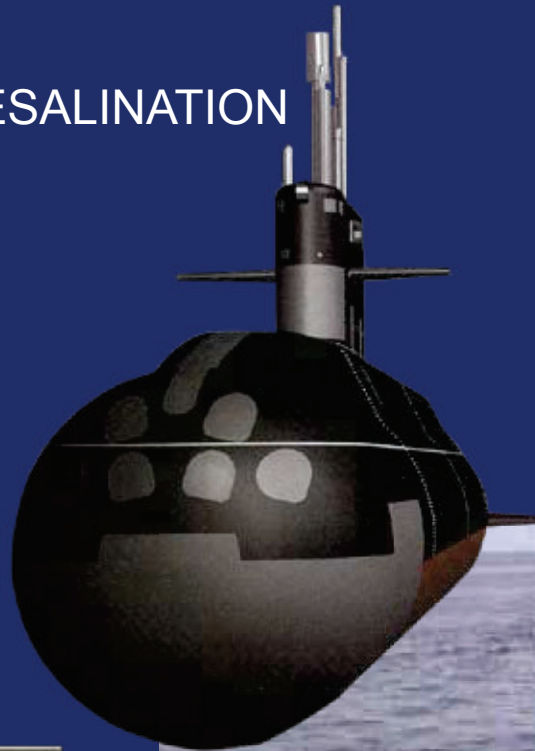

ROCHEM RO 9400
Freshwater capacity:
for example 2000ltr/day



NAVY'S- SUBMARINES with ROCHEM technology: Algeria (4), Brazil (3), Germany first 1986, Indian (4) first 1994, Israel (4), Italy (7) first 1988, South Korea (8) first 1990, Pakistan first 1991, Russia (6, special 4)

ROCHEM®

Technical Services

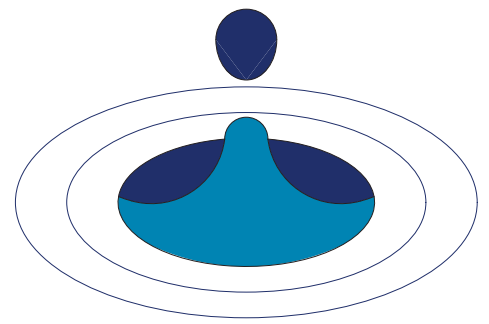

ROCHEM® REVERSE OSMOSIS FRESHWATER GENERATORS

ARE OF A HIGH RELIABILITY
PROVEN BY 25 NAVIES
WORLDWIDE



ROCHEM RO 1530-TS-35S
Freshwater capacity: 35 m³/day
fully automatic version with seawater preheating system.



Navies with ROCHEM technology: Australia/ 10 frigates, Brazil/ LPP-Ceará/Aircraft carrier/ 4 patrol boats, China/ patrol boats, Colombian SSS Gloria, Denmark/ Thetis class (4), Finland/ mine hunter (4), Germany since 1985/ more than 50 installation/latest: frigates (4), Hellenic since 1993/ all frigates, Indian/ frigates (4) more than 30 installation, Indonesia/ all landing crafts/ frigates (15), Italian since 1991 last frigates Fremm (4), Kuwait/ patrol boats (7), The United Arab Emirates/ since 1988/ 12 ships, Pakistan/ frigates (4), Portugal / frigates (4)/ corvettes (4), Malaysia/ frigate (1)/ LST, Thailand since 1991, Russia/ more than 48 ships, Spain/ since 1993, Turkey/ patrol boats/ coast guard, Venezuela/ POV/BVL 4 ships

ROCHEM[®]

Technical Services



ROCHEM®

Technical Services

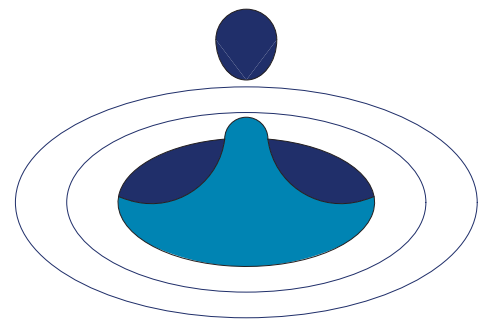

Ahead of the Regulations

The Rochem Group have developed systems that are ahead of the Marpol certificate standards. The Rochem Membrane Bio-Reactor (MBR) combined Black & Grey waste water treatment systems not only meet IMO/ Marpol standards but also meet discharge regulations for Miami Dade County surface water, US Coast Guard, US Public Health, Lloyd's and all current and forecast future standards.

The system is designed to treat combined Black & Grey waste waters from sewage, galley (after grease trap unit), accommodation & laundry grey waste waters.

The process in principle is essentially the same for 20 persons or 4000 persons by (to simplify) changing the number of bio-reactors and membrane modules to suit the waste water volume.

The main components of the combined black and grey water treatment plant are the pre-filtration stage, bioreactor segments and the ultra-filtration modules. The clean effluent (filtrate) is passed to a small tank for further use or discharge. The bio-waste/ excess sludge produced in the aerobic digestion of the black- and grey- water ingredients is collected in a bio-waste tank for disposal or further treatment such as drying, and or incinerating, etc.

Yacht builders/ owners internationally including Royal De Vries/ Feadship have contracted the Rochem MBR Systems for their Luxury yachts.

Rochem provides customised system designs and an international spares and maintenance service.

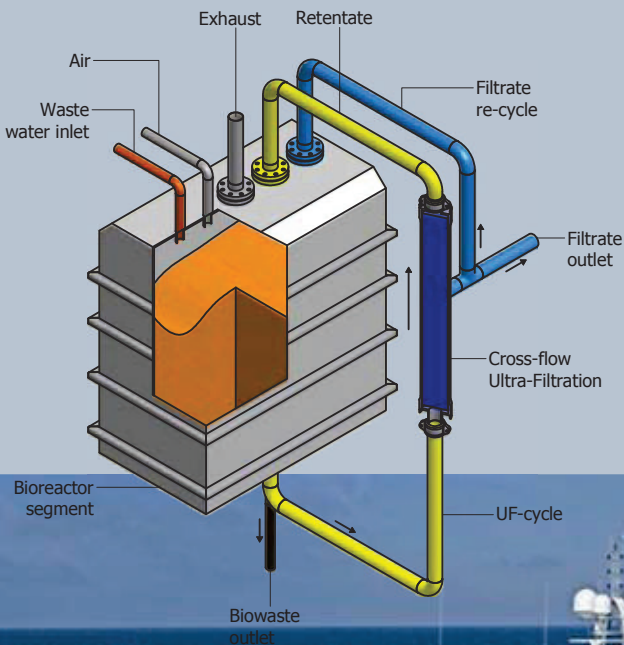

ROCHEM®

Technical Services



since 1998 on the research ship POLARSTERN
PORTABLE WATER AND MBR SEWAGE TREATMENT

ROCHEM® - MEMBRANE- BIO- REACTOR

REVERSE OSMOSIS DESALINATION



ROCHEM MBR®

Membrane Bio Reactor

Turn sewage from toilets, sinks, basins, showers, kitchen and laundry to clean environmental- friendly water that meets the bath water quality according to EU-standarts.

USE OUR EXPERIENCE

ROCHEM[®]

Technical Services



Improved technology for water purification with ROCHEM MBR Membrane Bio Reactor

The combination of a high density biomass reactor with the UF module system for ultrafiltration forms the operating unit of the membrane bioreactor ROCHEM MBR which gives many advantages for waste water treatment

ROCHEM SOLUTION

The efficiency of the Membrane Biological Reactor allows for the purification of black water on ships to achieve a quality superior to the international limit values for contaminants imposed by MARPOL/IMO. Therefore the environmentally sound purified waste water can be discharged overboard in any harbour or coastal area.



since 2002 on the M/V *SEABOURNE PRIDE*,
140 m³/day

COMPREHENSIVE WATER MANAGEMENT

Seawater Desalination and waste water treatment on ships and offshore platforms

ROCHEM serves the needs of the ship's crews and offshore platform's operators for high-quality drinking water and for environmental-friendly waste water treatment.

ROCHEM REVERSE OSMOSIS FRESHWATER GENERATORS:

- Clean sterilize and desalinate seawater to high quality pure potable water
- Use the ROCHEM TS modules , that have been specially developed for the operation in polluted coastal areas
- Are state-of-the-art due to more than 25 years of experience
- Have proven reliability, are emitting low noise and are easy to operate
- Are approved by all well known classification societies
- Do not need any chemicals pre-treatment
- Are selfcontrolled for safe operation by unskilled personnel



Accommodation Barge ERSAI 400 on Caspian Sea is equipped with a MBR sewage treatment plant for a capacity of 120 m³/ day and 3 x 50 m³/day ROCHEM RO-Freshwater Generators



NO CHEMICALS NEEDED FOR OPERATION

ROCHEM® - MEMBRANE- BIO- REACTOR

- Turn sewage from toilets, sinks, kitchen and laundry to clean environmental-friendly water that meets the bath water quality according to EU-standards
- Are equipped with the scientifically designed high-load biomass bio-reactor ROCHEM MBR for an efficient natural pre-treatment
- Do not need any chemicals to meet the specific values of the most stringent international requirements, such as IMO resolution MEPC.159(55), Annex IV

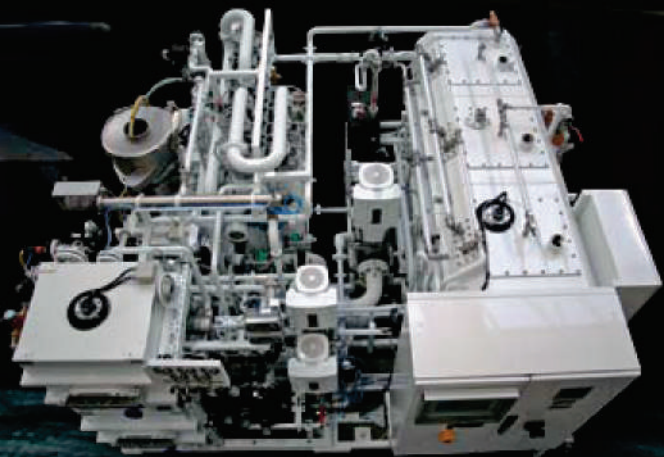

ROCHEM®

Technical Services

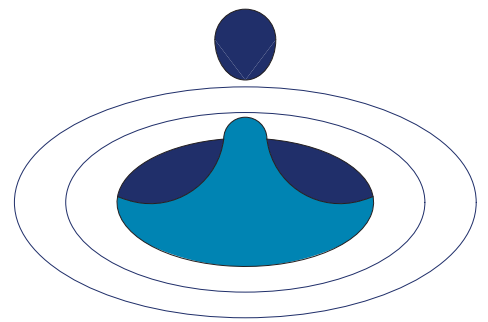

ROCHEM MBR

These five units are installed on ships in the Caribbean, for treating the gray and black water

ROCHEM® - MEMBRANE- BIO- REACTOR SKID MOUNTED

The reliable function of this process and the operating safety of the membrane filtration and bioreactor technology have been proved in a multitude of operating systems over many years.

The bioreactor is manufactured as modular multi- tank construction from stainless steel. The adaptation to the purification demand is achieved by the respective design of the compact operating units.

The ultrafiltration unit consists of ROCHEM UF- Modules, where the combination of open channel construction and narrow gap technology allows for a highly efficient cleanability and high availability- and thus for safe and economic operation.

The purification plant itself ensures an automatic, reliable and fail safe operation with a minimum of maintenance and high availability. This is due to a construction that is adapted to the client's needs by a well established manufacturing quality assurance system and PLC based process control.



ROCHEM MBR

skid mounted with bio reactor UF-Modules, control cabinet, pumps and blower measuring and control equipment, ready for operation



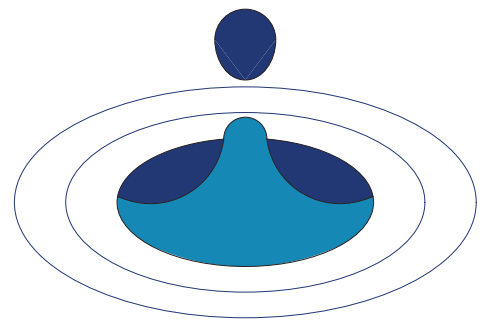

TREATMENT OF BLACK WATER WITH ROCHEM® MBR MEMBRANE- **BIO- REACTOR**

Black water, or sewage, is characterized by a high content of particulate and organic matter. Elevated values for suspended solids, uncountable numbers of microorganisms (like fecal bacteria) and high values for the biochemical oxygen demand (BOD) show that this liquid waste is very harmful to the environment.

Conventional biological waste water treatment relies on large aeration and settling tanks. However, space and weight are limiting factors for the installation of treatment systems on ships. The solution to this problem is the MBR system, a combination of the UF membrane system with a proprietary bioreactor developed by ROCHEM based on the company's experience with on board and offshore related water treatment technology since 1982.

The biological reactor equipped with an **ULTRAFILTRATION MODULE** can achieve high biological degradation factors.

As the ultrafiltration membrane is a physical barrier, the disinfected effluent meets every discharge standard- similar to or better than land based plants.

The high purity of the MBR effluent allows discharge of this water meeting international regulations.

TREATMENT OF EFFLUENT FROM THE MBR WITH ROCHEM LOW PRESSURE REVERSE OSMOSIS

The growing concern in recent years around the world regarding environmental pollution, the anticipation of tightened global waste water discharge regulations and the rising costs for waste handling in ports are the main driving forces for the development of solutions that contribute to a "green ship concept" or an "environmentally sound ship". The high volume of gray water discharged overboard due to the increased number of passengers, ranging from 1000 up to 5000, on cruise ships and ferries causes severe danger to the environment as most of this waste water goes untreated.

MBR treated water can be treated to high purity standards with ROCHEM TS module systems utilizing low pressure reverse osmosis membranes. This membrane rejects all bacteria, all kinds of suspended solids, as well as, dissolved salts, metals and organic contaminants.

The TS module configuration assures a high reliability and filtration performance with a high degree of purification. No chemicals or disinfectants will be necessary for achieving a pure effluent which can be passed overboard at any location, or reused as technical water on board.

ROCHEM delivers the plants as standardized factory tested units, modularly constructed in sections with feed capacities from **6.000m³/day to 100.000m³/day**, offering fully automatic operation, simple handling, and low maintenance requirements.

The purity of the water produced by the TS module is sufficient to allow for the reuse of the water for many on board applications including laundry make up, boiler make up, and deck washing.

ROCHEM®

Technical Services

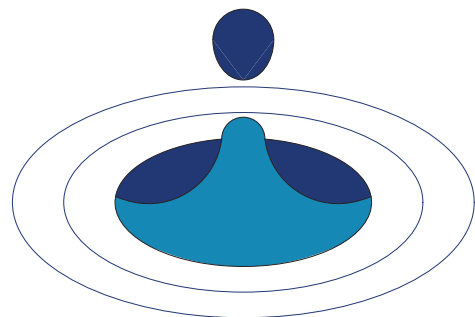

REVERSE OSMOSIS DESALINATION SINCE 1982 ON OFFSHORE-PLATFORMS

Saipem belongs to the ENI Group, which is a large international turnkey contractor in the oil and gas industry. It is a leader in providing engineering, procurement, project management, and construction services with specialization for large scale offshore projects in deep water and remote areas.



ROCHEM® REVERSE OSMOSIS FRESHWATER GENERATORS

are in operation at Saipem Offshore-Platforms

Saipem Castor VI/ 80m³/day (1987)
Saipem Maxita/ 3x 160m³/day (1991)
Saipem Crawler/ 2x 80m³/day (1994)

followed by various sized systems
to Castoro 8, Catoro 7, Perro Negro,
Saipem Ersai 400



TREATMENT OF BLACK WATER WITH ROCHEM® MBR MEMBRANE BIO- REACTOR

Saipem Ersai 400

for treating all the black and grey water
generated on board by the crew.



FRESHWATER GENERATORS for POTABLE WATER on: Castoro V/1987(80.000litr/day), Castoro VI/1991(60.000litr/day), Maxita/1991(180.000litr/day), Crawler/1994(160.000litr/day), Castoro VIII/1992(160.000litr/day), Castoro VIII/1998(120.000litr/day), Perro Negro/2002(80.000litr/day)

ROCHEM®

Technical Services

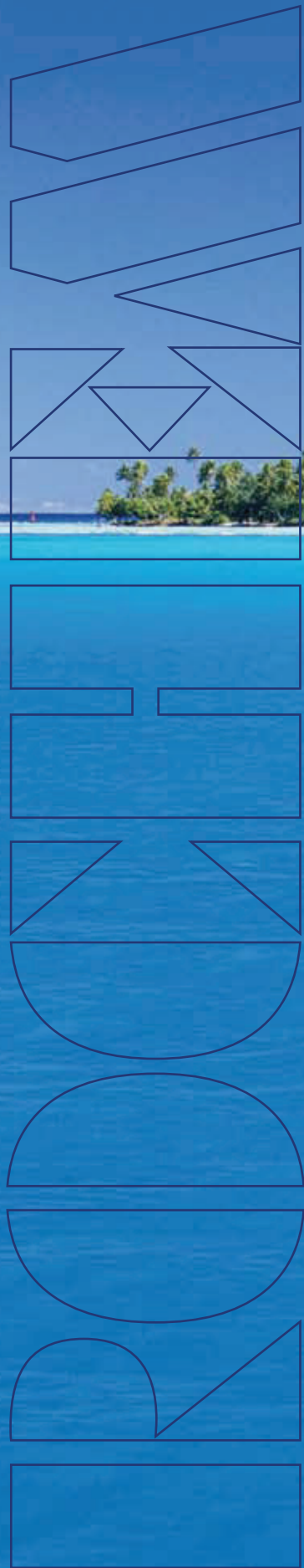
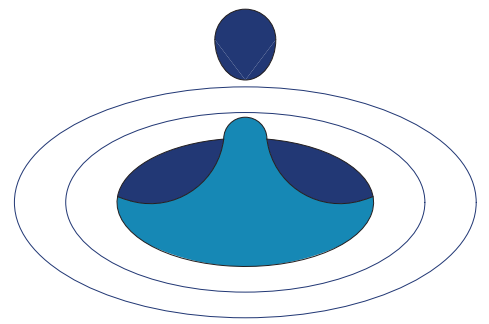

WE PURIFY THE WATER
YOU JUST ENJOY IT

ROCHEM®

Technical Services

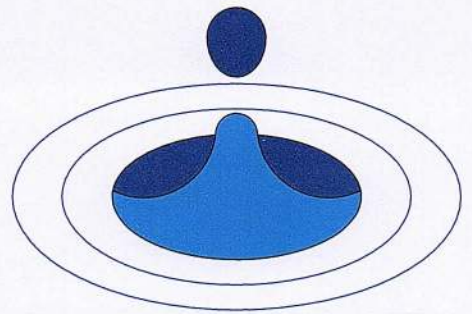

- SERVICE
- MAINTENANCE
- SPARE PARTS
- STANDARD PLANTS
- NEW BUILD
- CUSTOMER FOCUSED
- SPECIAL DESIGN
- OWN MANUFACTURER

ROCHEM® AMERICAS

426 30th Street Hermosa Beach, CA 90254
Tel. 310-374-0202 www.rochemamericas.com



RTS ITALY Srl unipersonale

Via D. Fiasella 10/12
16121 Genova (Italy)

Tel: +39 010 9868074
Fax: +39 010 9868075

www.rts-italy.it - info@rts-italy.it

ROCHEM® Technical Services GmbH

Knickberg 1a
D-21077 Hamburg, Germany
Tel: +49 (0) 40 703 85 77-13
Fax: +49 (0) 40 703 85 77-29

Heine@rts-rochem.de



ROCHEM®
TECHNICAL SERVICES

Established in 1978

RTS Europe
UK
www.rochem.net
sales@rts-europe.co.uk